

### Fräseraufnahme $\varnothing 16h6 \times 10$

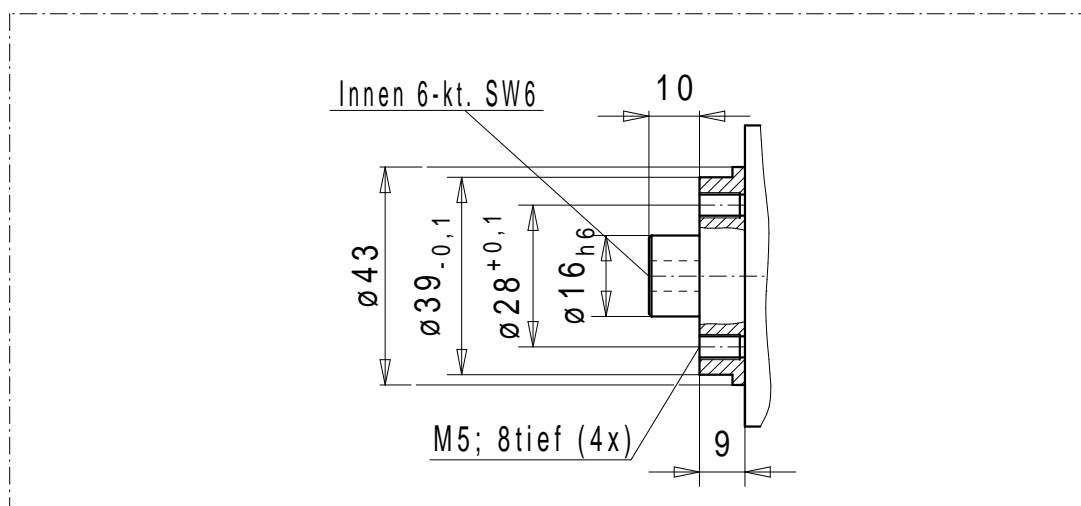

### Schaftaufnahme $\varnothing 10H7$

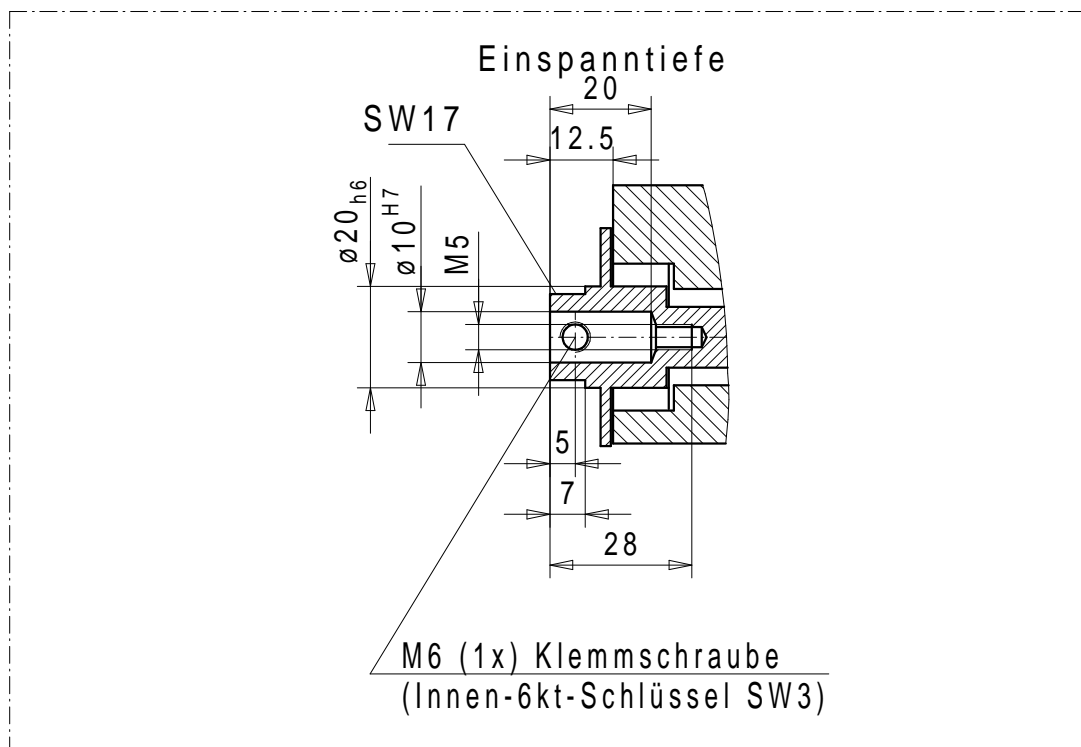

### Spannzangenaufnahme Hi-Q/ERAX 20

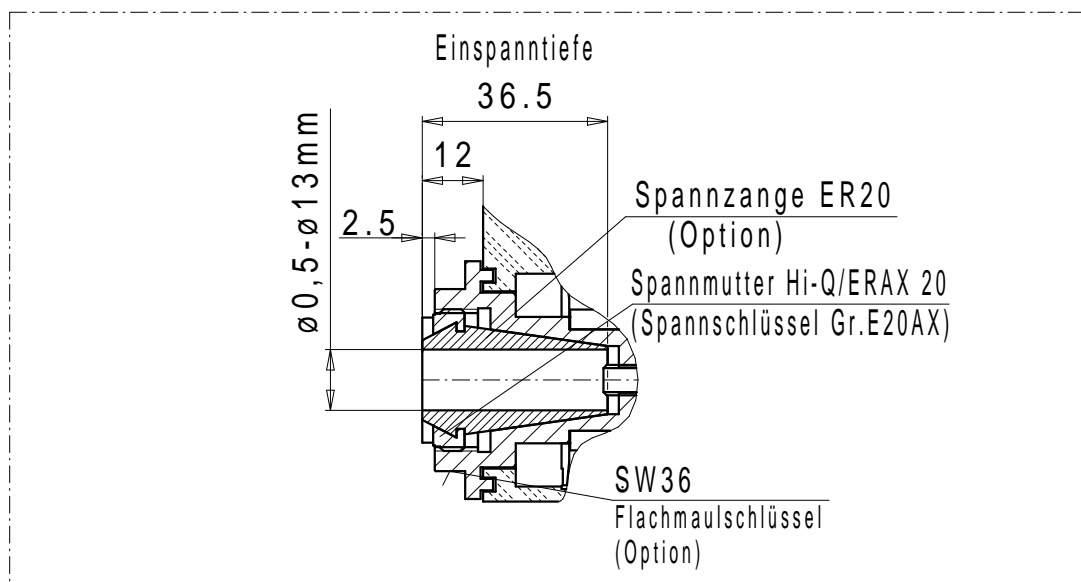

### Spannzangenaufnahme HI-Q/ERAX25 mit Innengewinde

