

Drive adapter

Standard configurations and
machine specific executions upon request

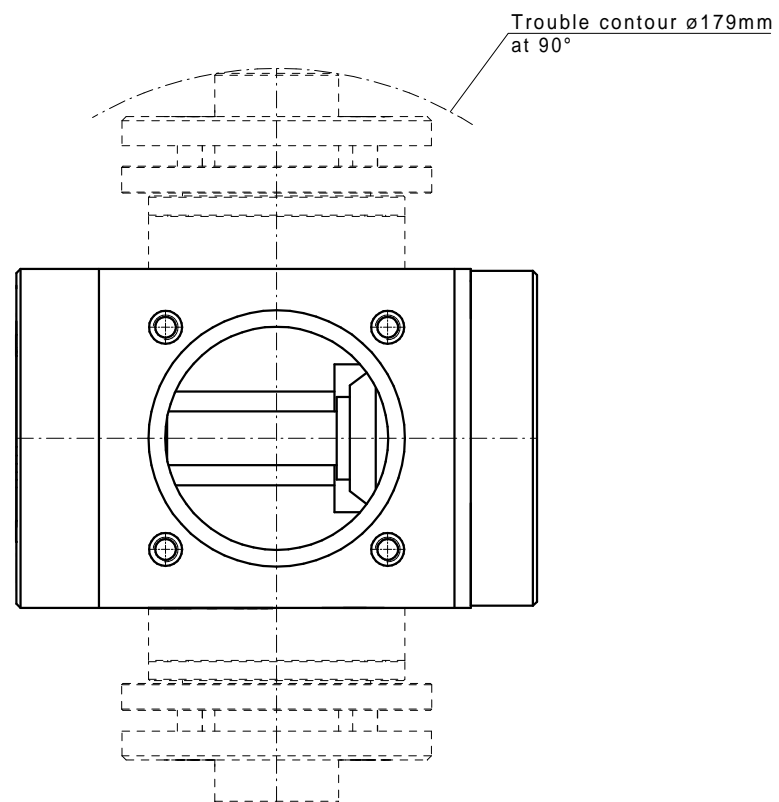

Sawing-/Drilling receptacle

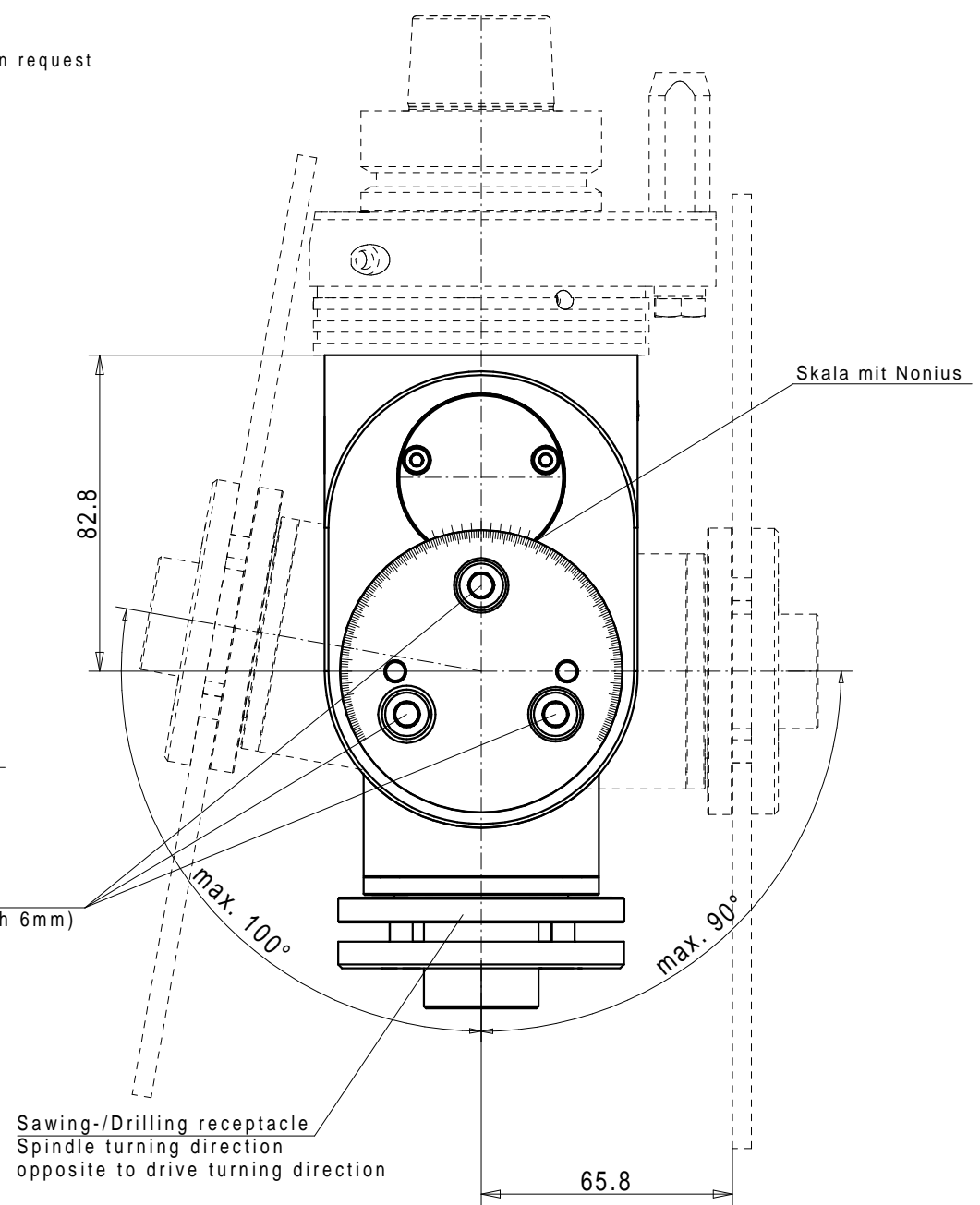
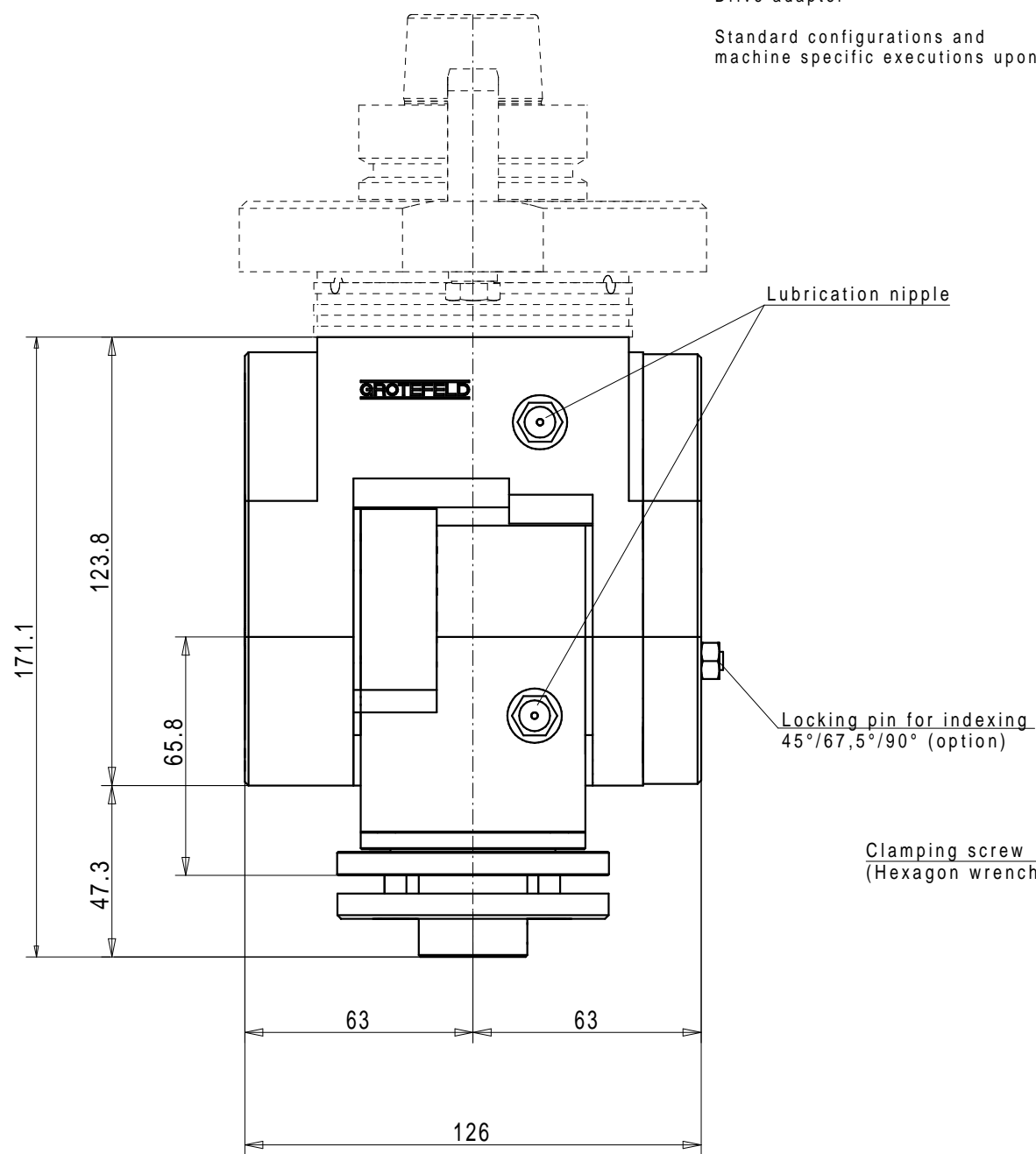