

Drive adapter

Standard configurations and
machine specific executions upon request

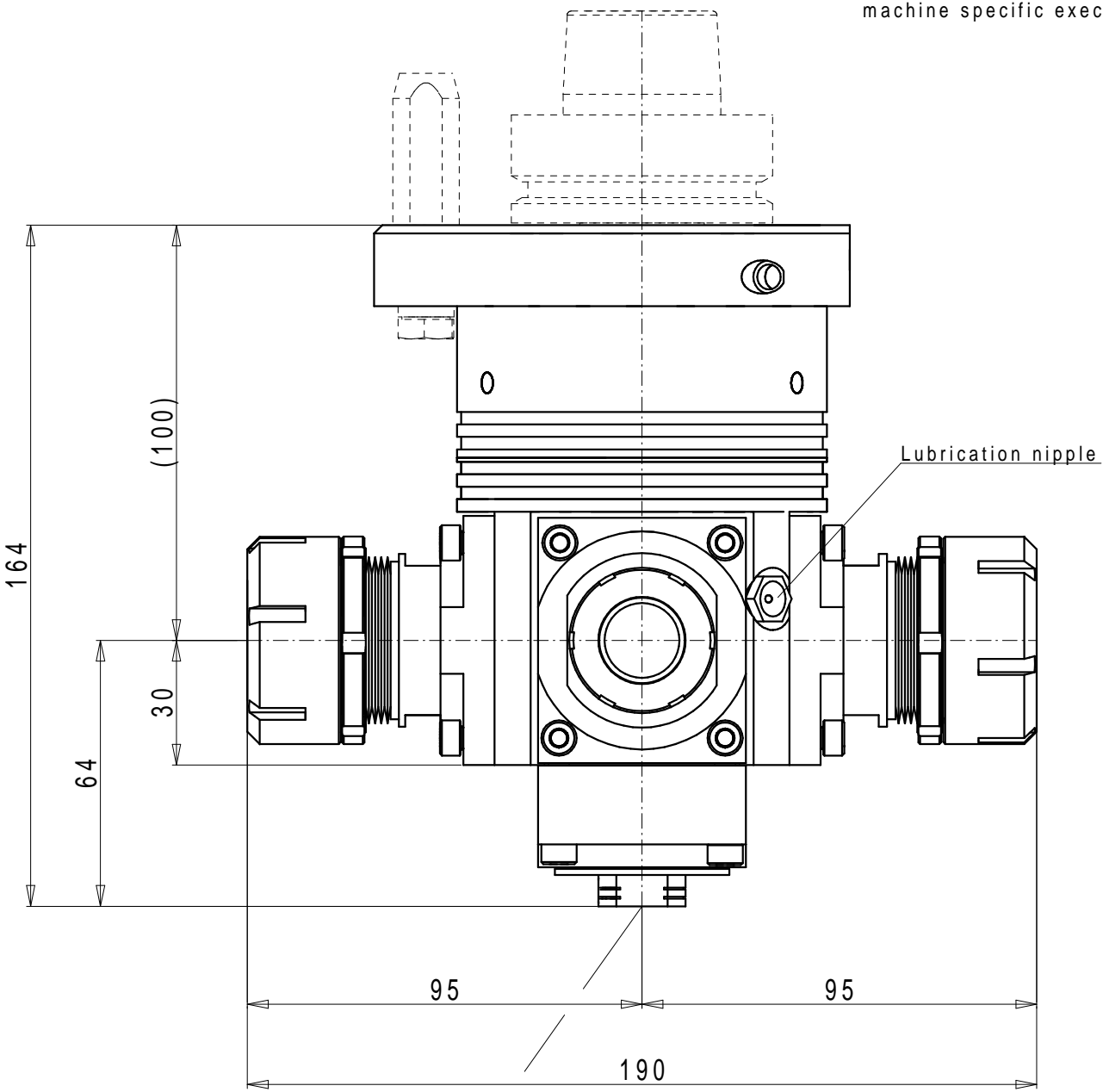

Collet receptacle Hi-Q/ERM25

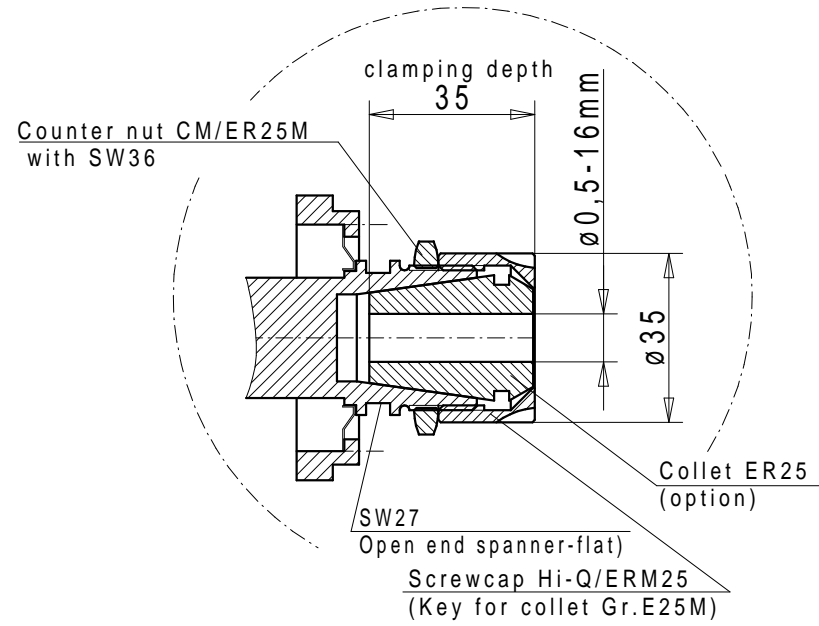

Collet receptacle Hi-Q/ER32

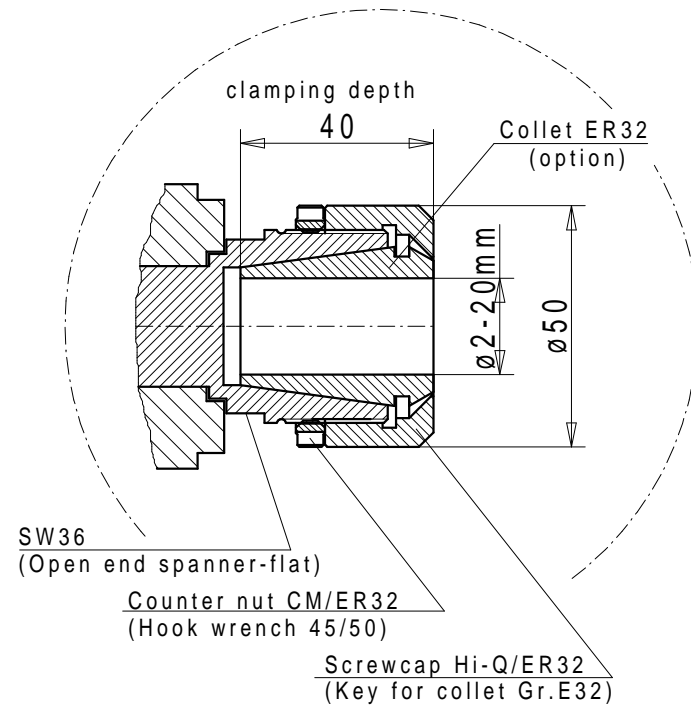

Spindle turning direction opposite
drive turning direction

Spindle turning direction equal
drive turning direction

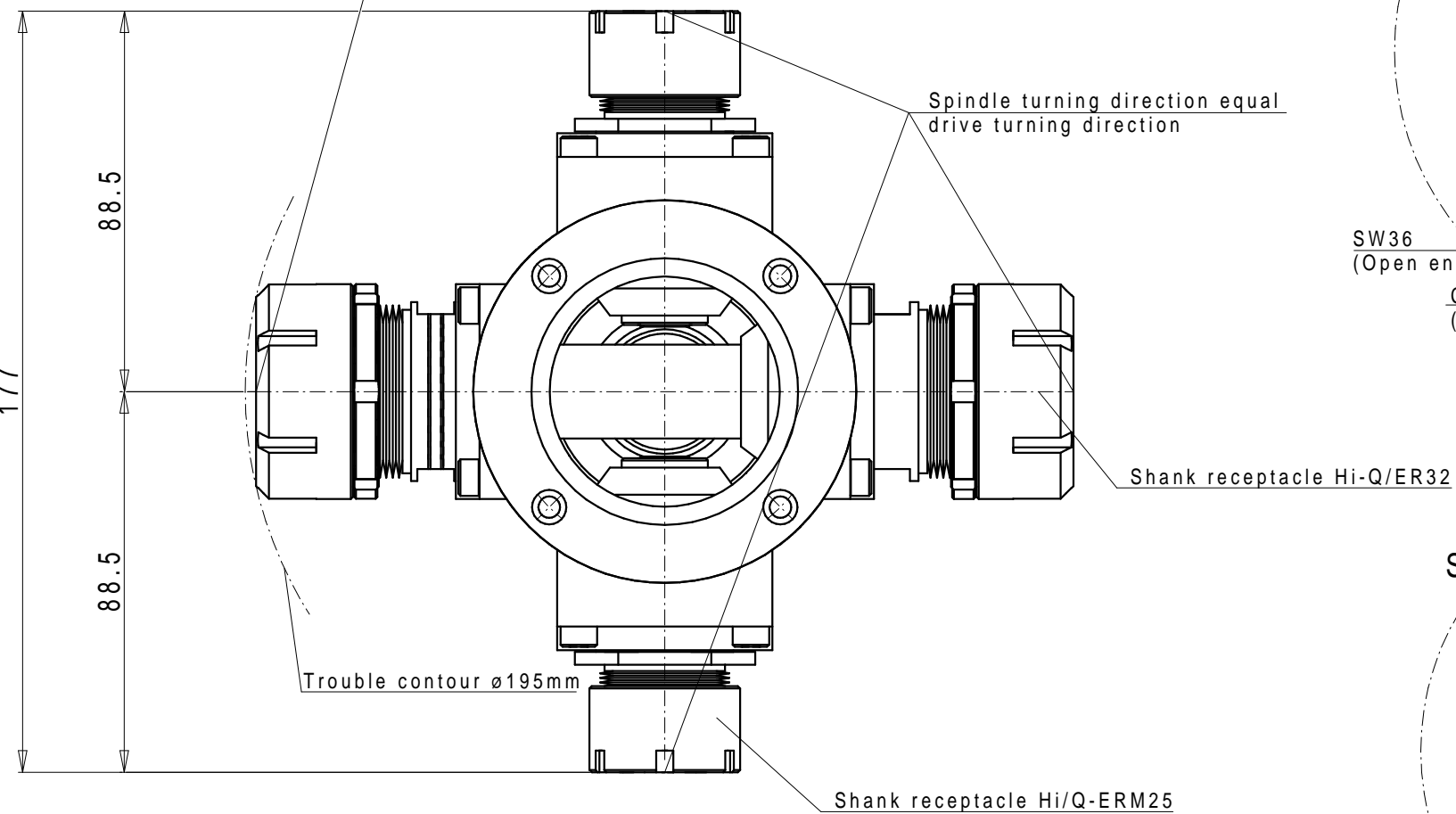

Shank receptacle $\varnothing 10\text{H7-L.H.}$

