

Drive adapter

Standard configurations and machine specific executions upon request

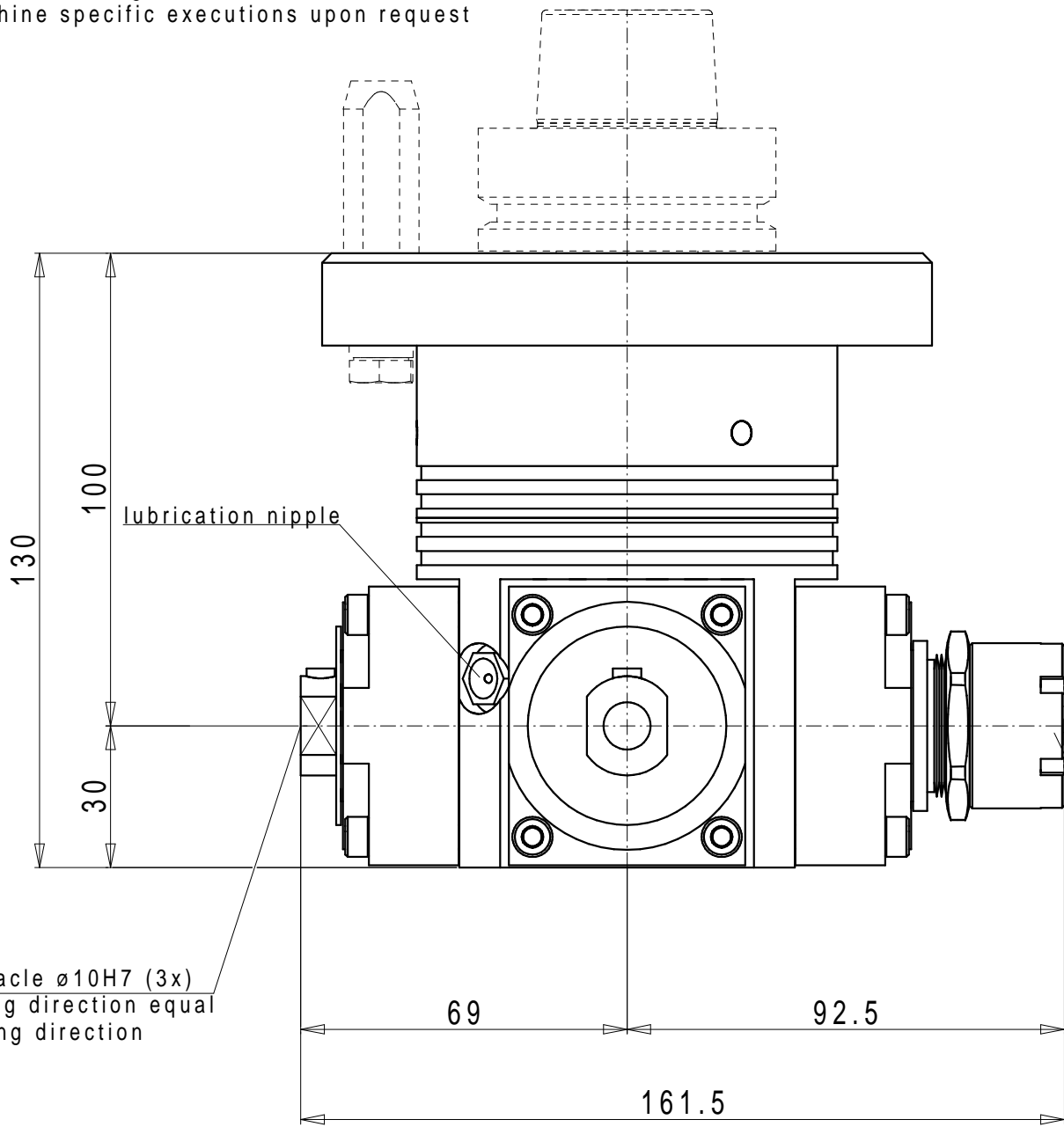

Collet receptacle Hi-Q/ERM25

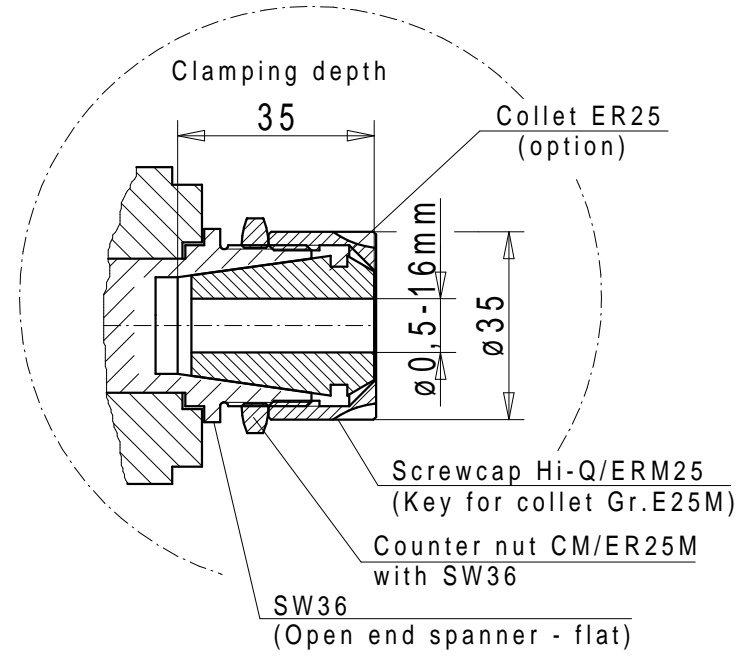

Collet receptacle Hi-Q/ERM25 spindle turning direction equal to drive turning direction

Shank receptacle $\phi 10H7$ (3x) spindle turning direction equal to drive turning direction

Shank receptacle $\phi 10 H7$

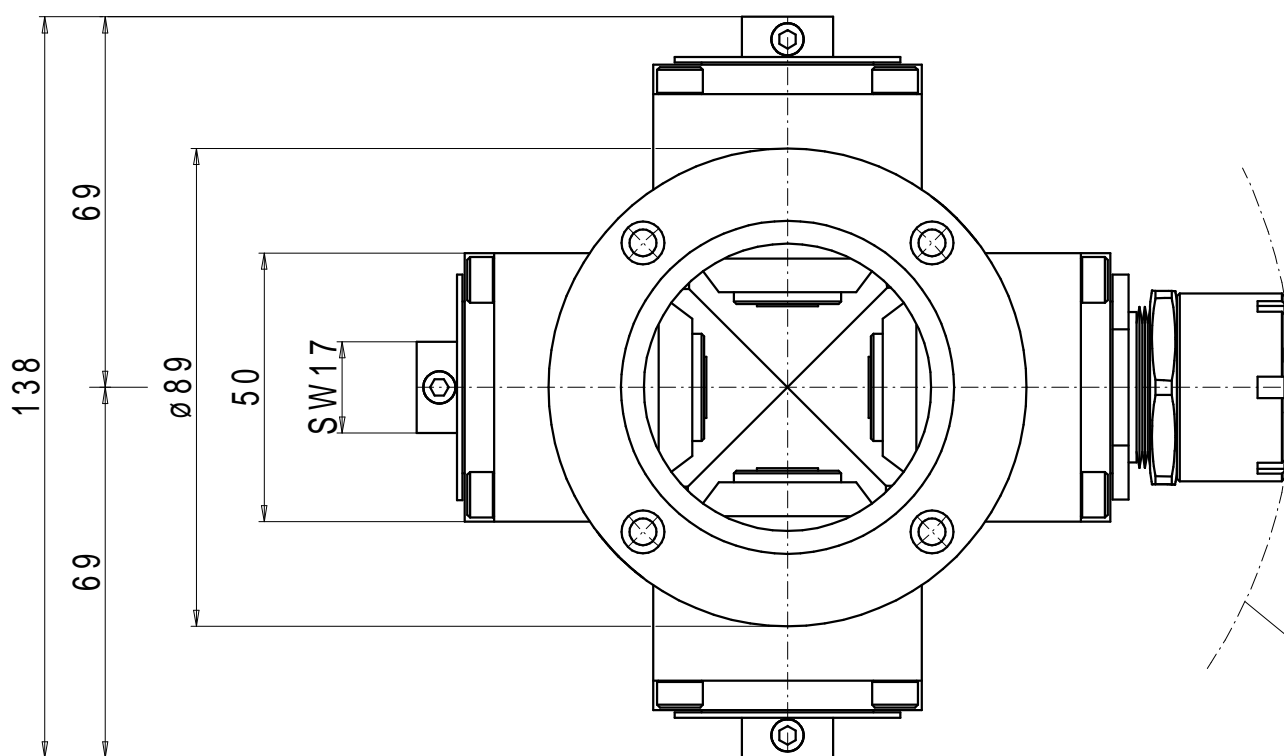

Binding screw M6 (1x) (Hexagon wrench 3 mm)

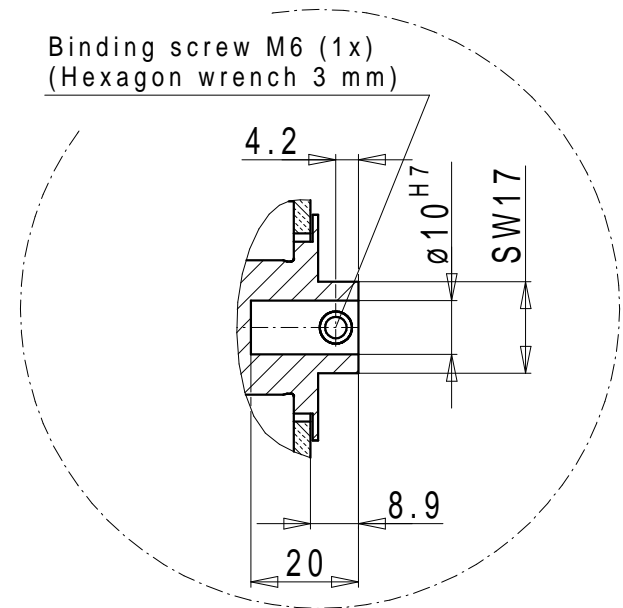

Trouble contour $\phi 189$ mm