

Drive adapter

Standard configurations and machine specific executions upon request

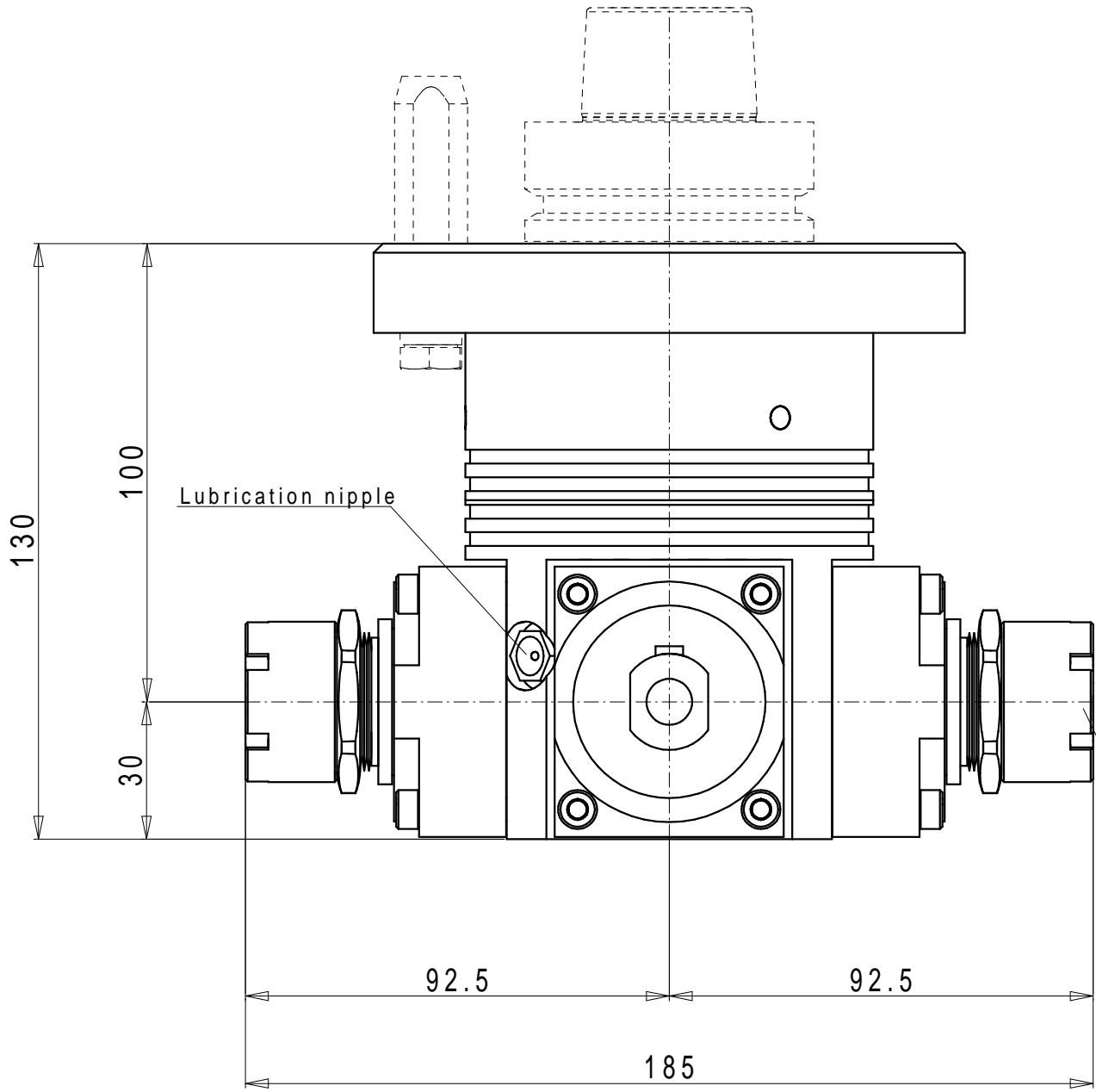

Collet receptacle Hi-Q/ERM25

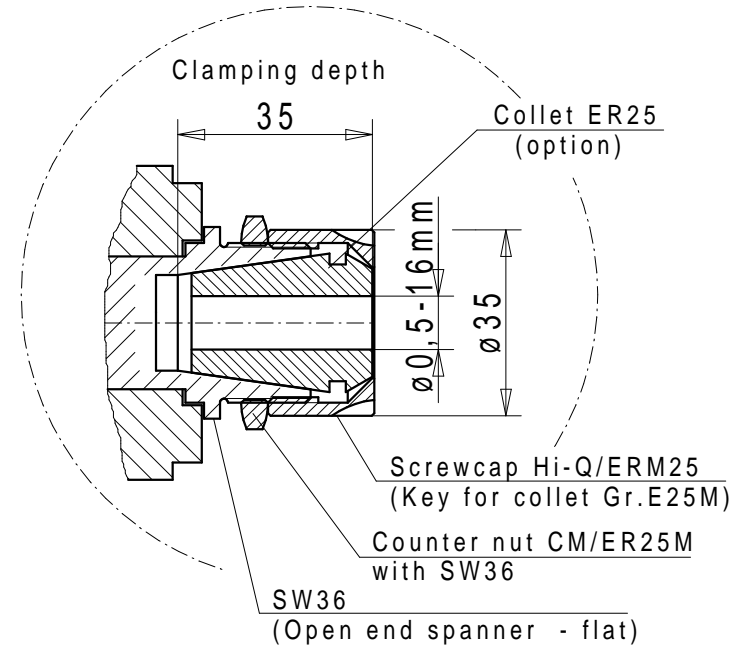

Shank receptacle Hi-Q/ERM25 (2x)
spindle turning direction equal to drive turning direction

Shank receptacle $\varnothing 10\text{ H7}$

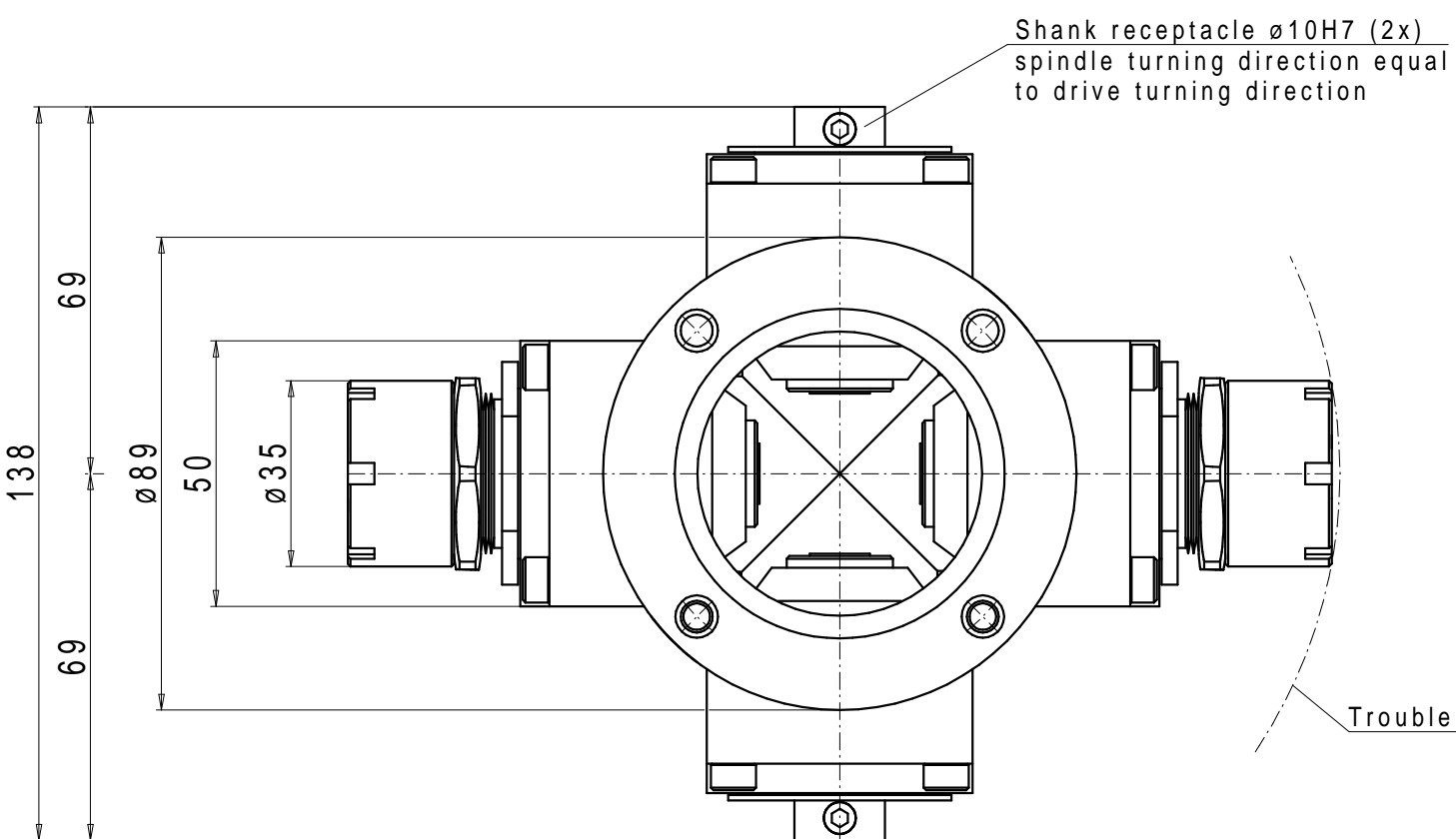

Binding screw M6 (1x)
(Hexagon wrench 3 mm)

