

Drive adapter

Standard configurations and machine specific executions upon request

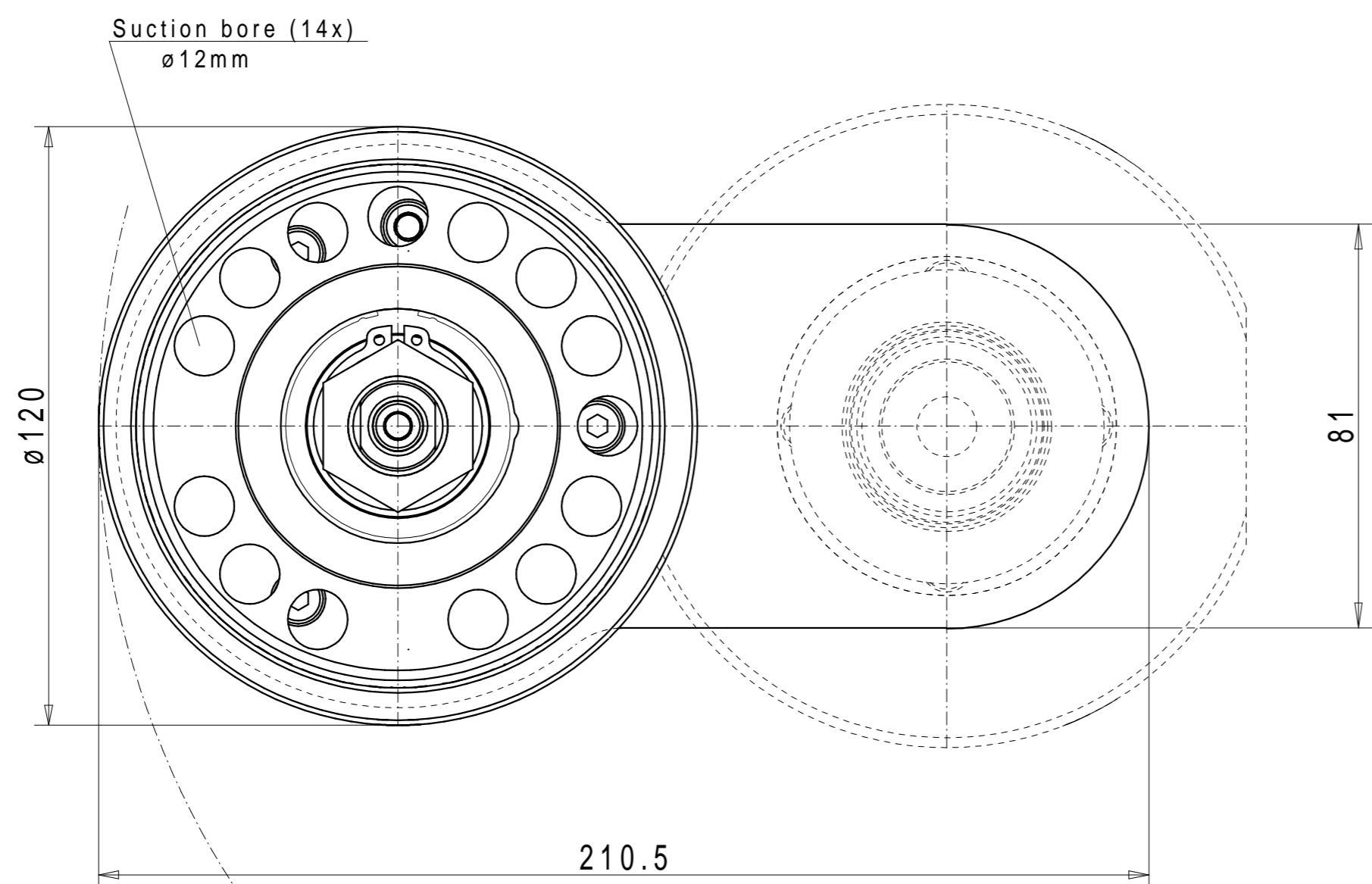

Trouble contour $\varnothing 340\text{mm}$

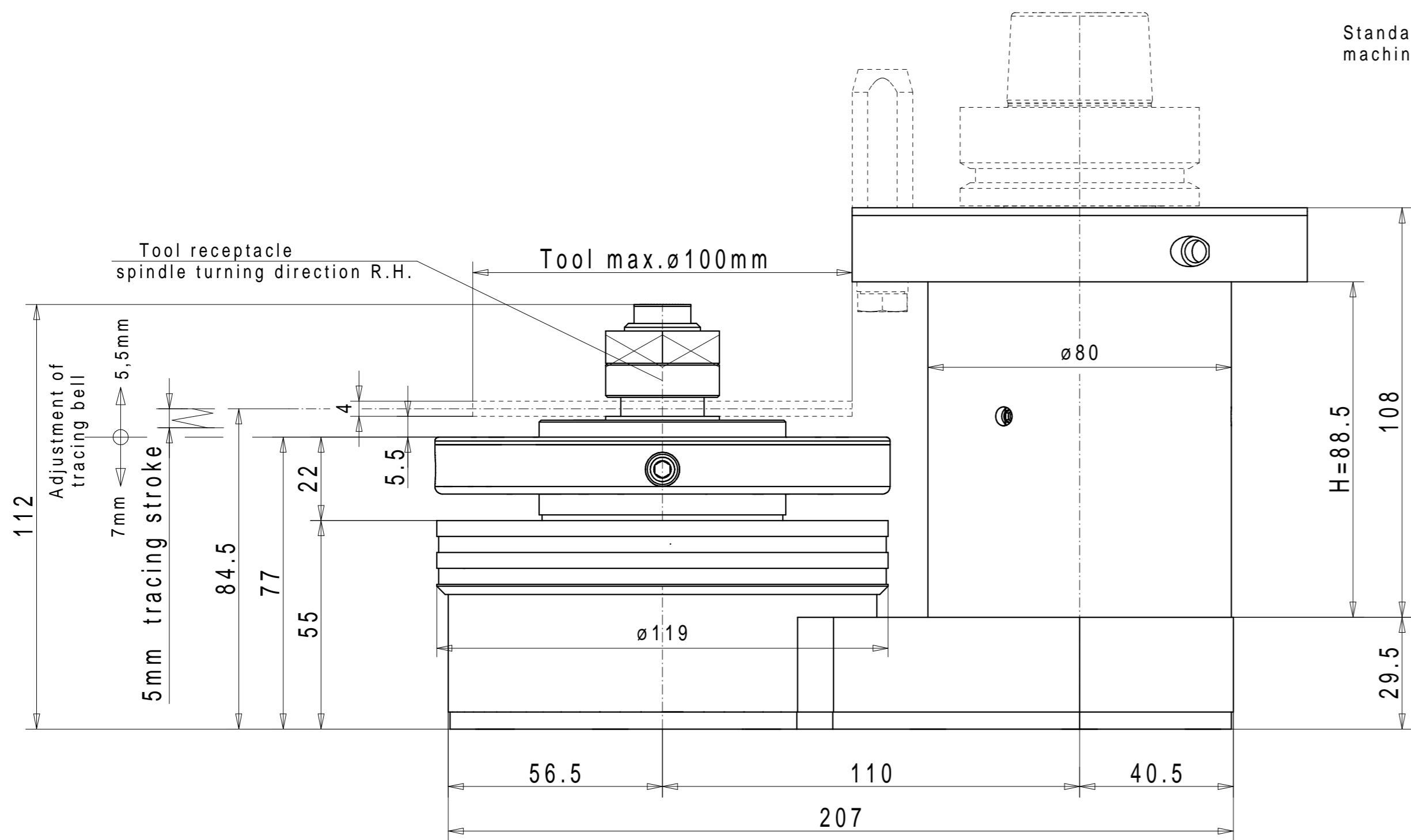
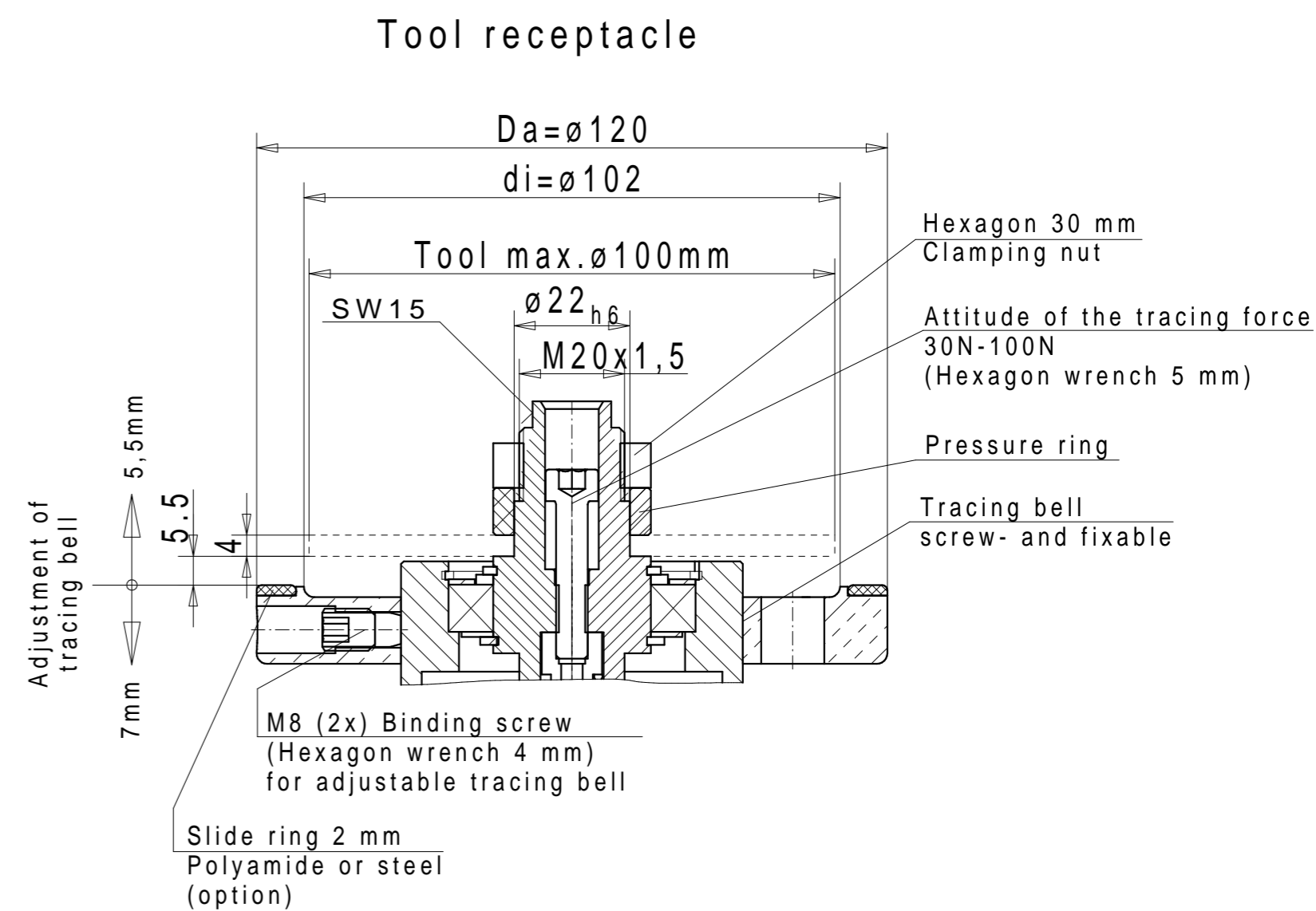

For the perfect performance of the spindle it is important that the dust extraction in the tool cutting area works best possible!
Stroke length of tracing spindle is 5mm !