

Drive adapter
 Standard configurations and machine specific executions upon request

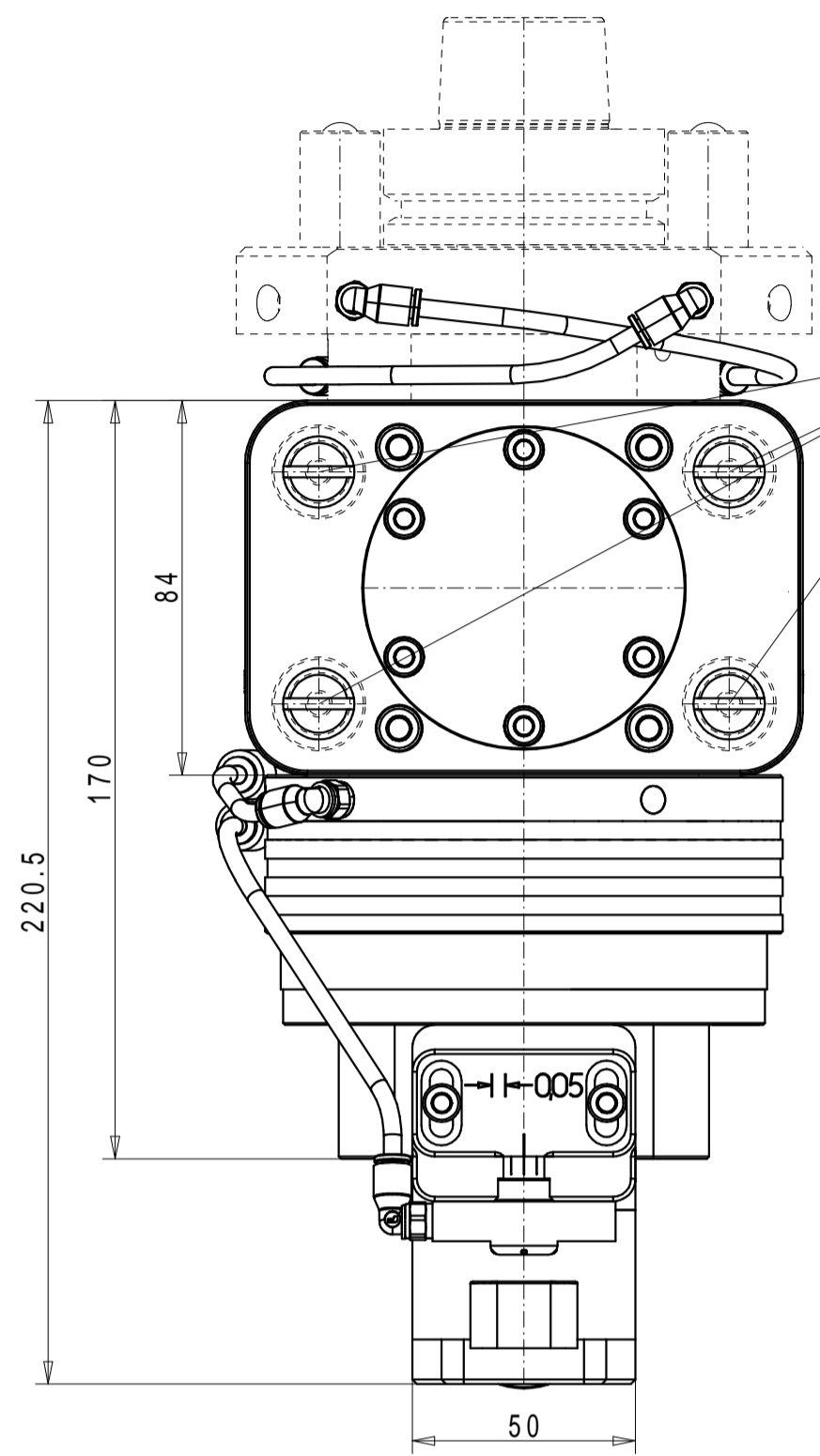

Drive adapter changeable 2x180°

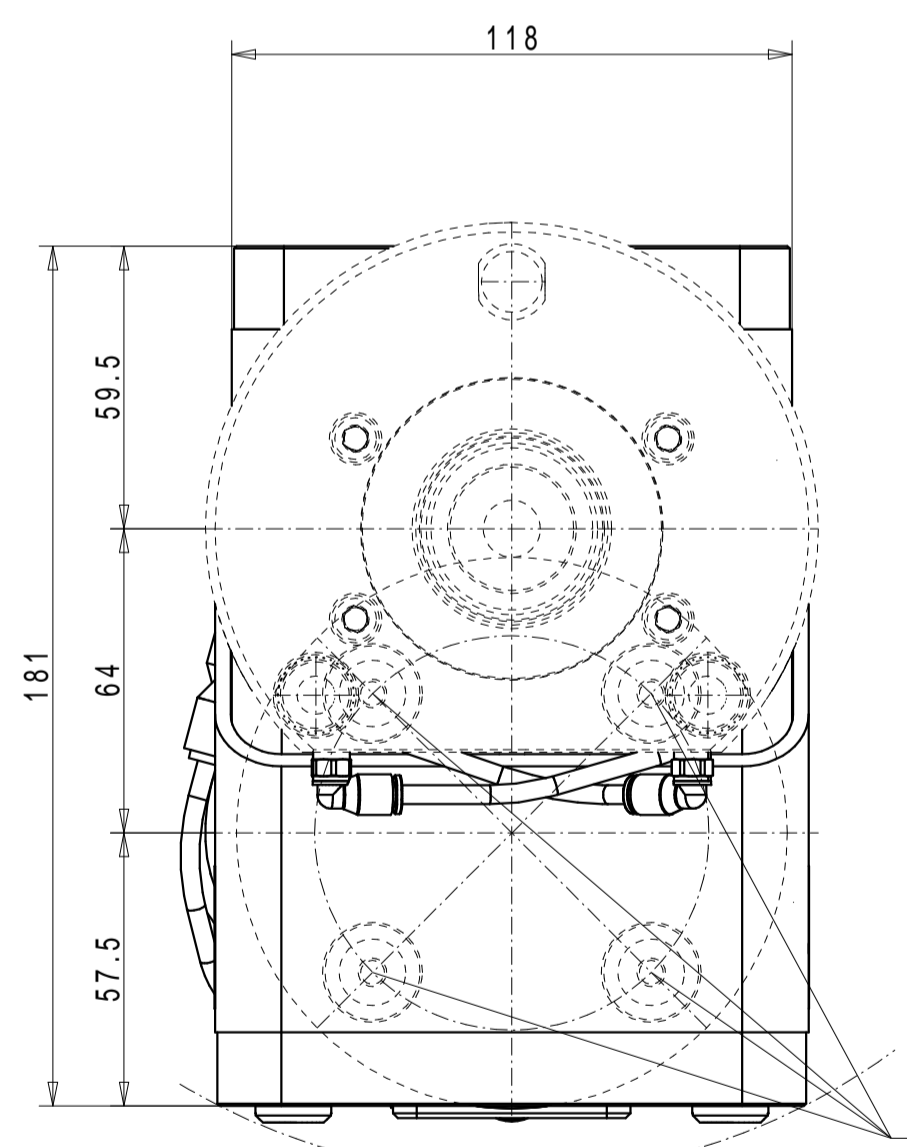
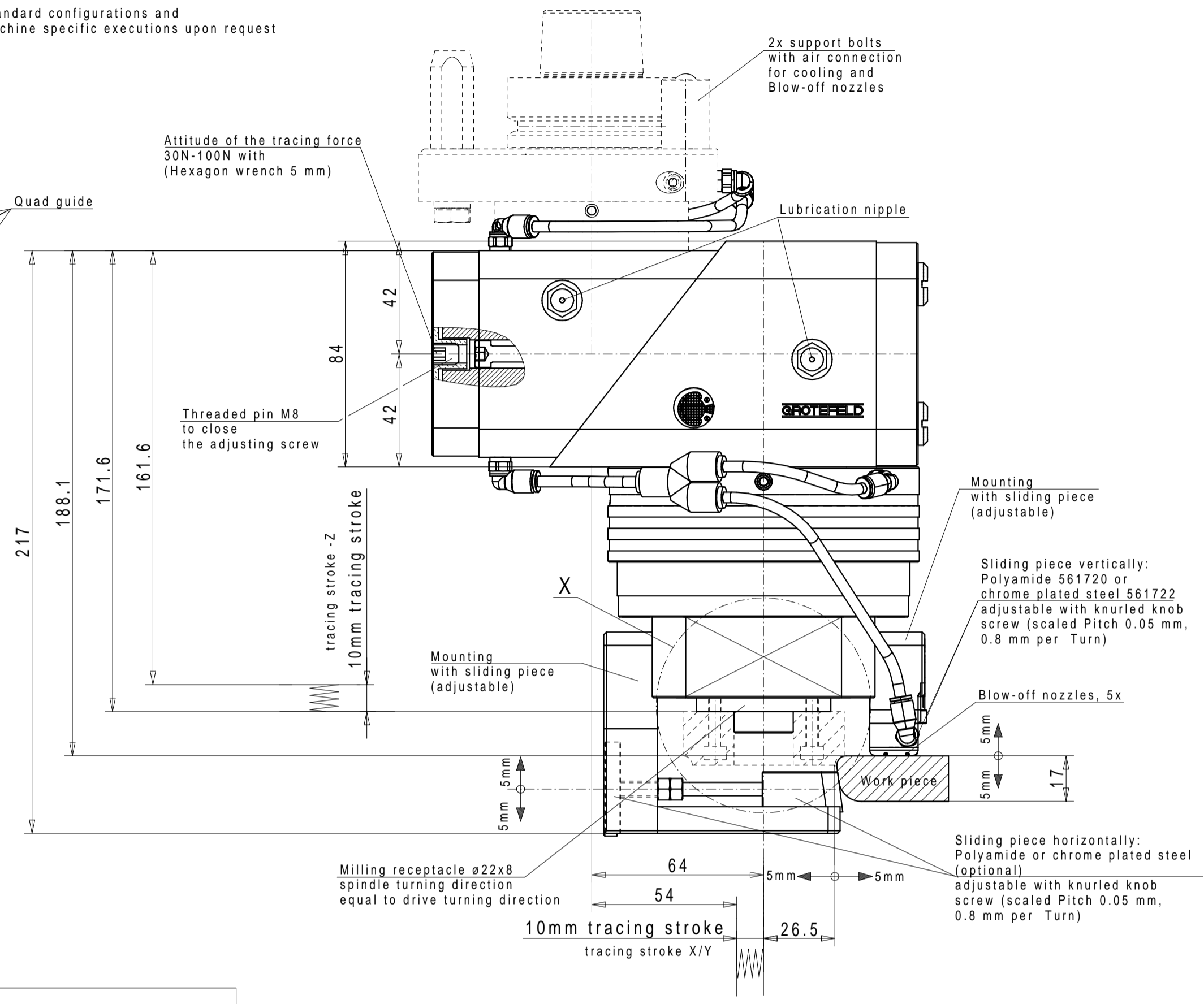

Note
 For 1-sided edge processing engine without spindle Rotation axis
 For multipage edging motor spindle with Rotation axis is required

Milling receptacle ø22h6 x 8

