

Dargestellt ist die Einheit mit 2,2kW - 150 mm Hub Ausführung LINKS

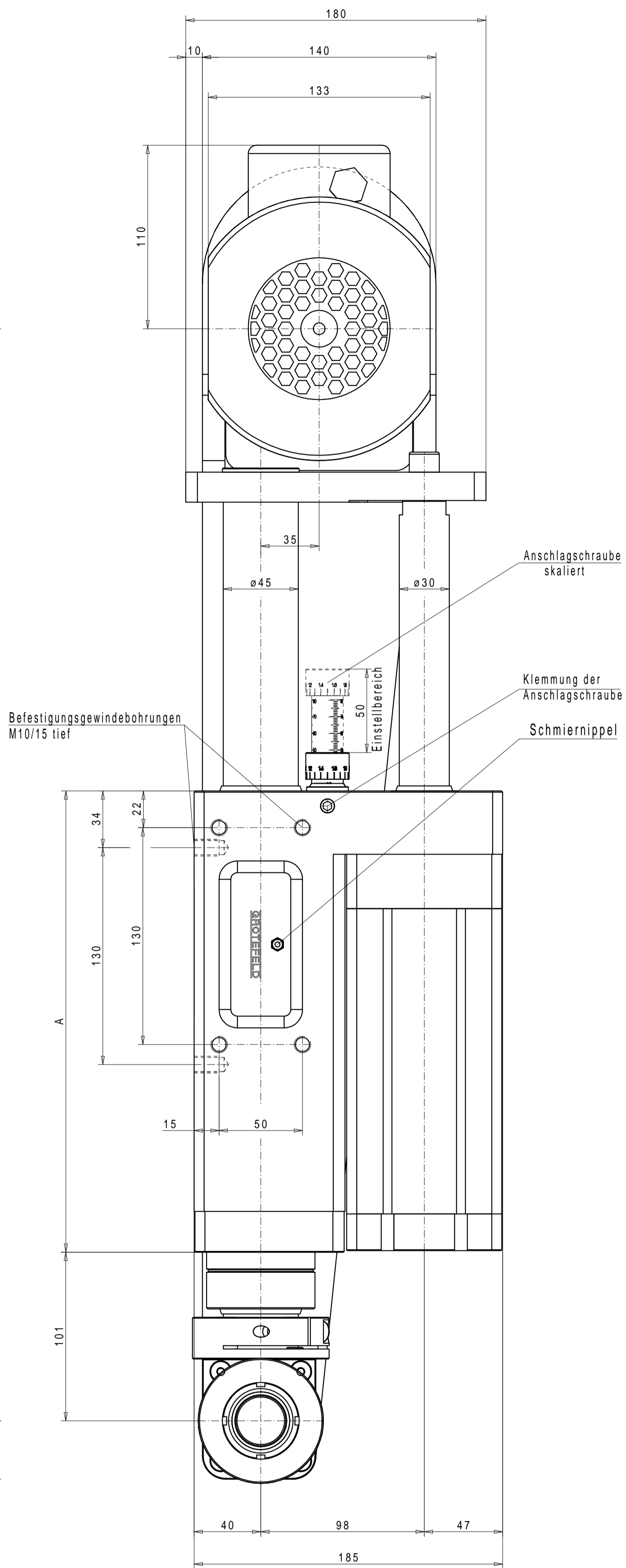

### Fräseraufnahme

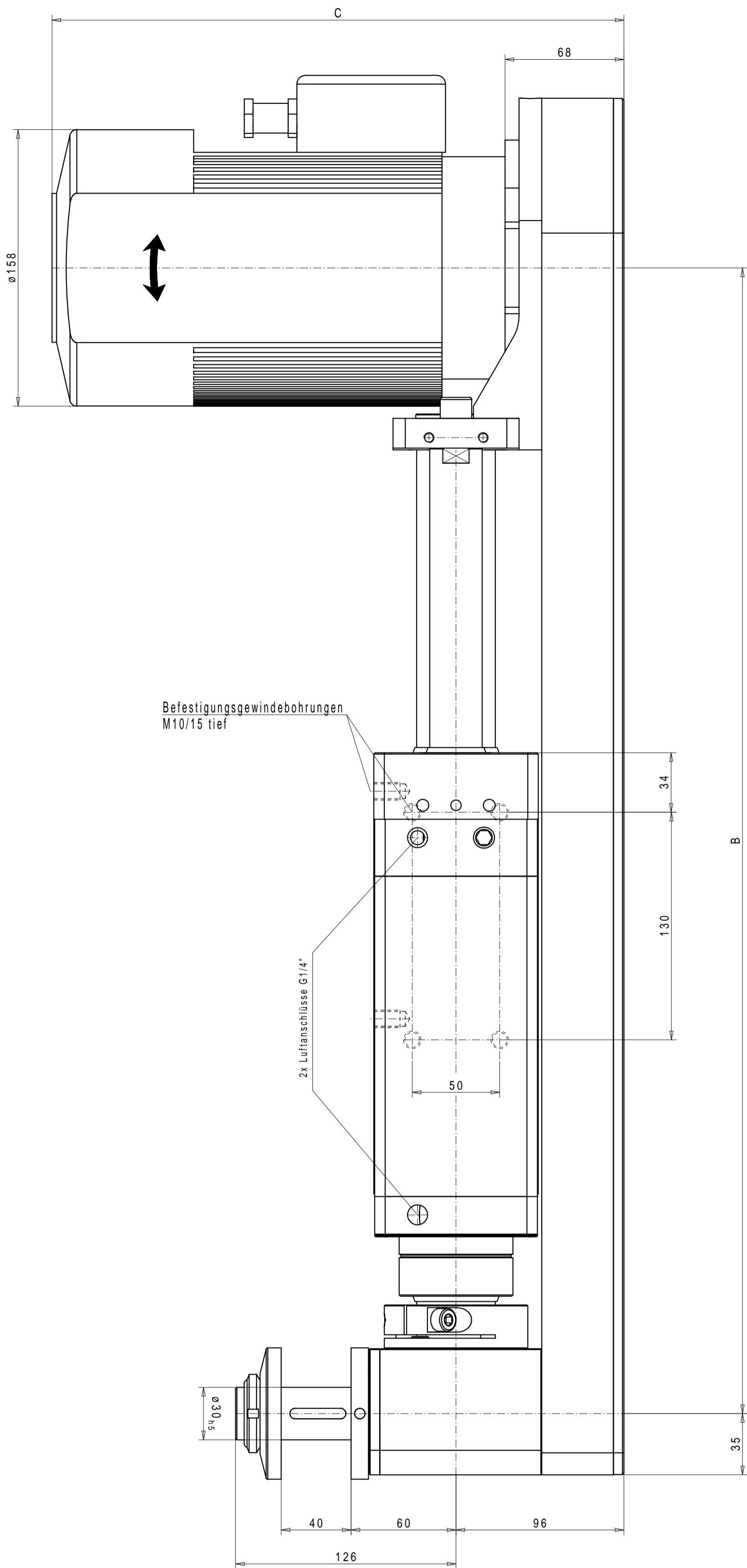
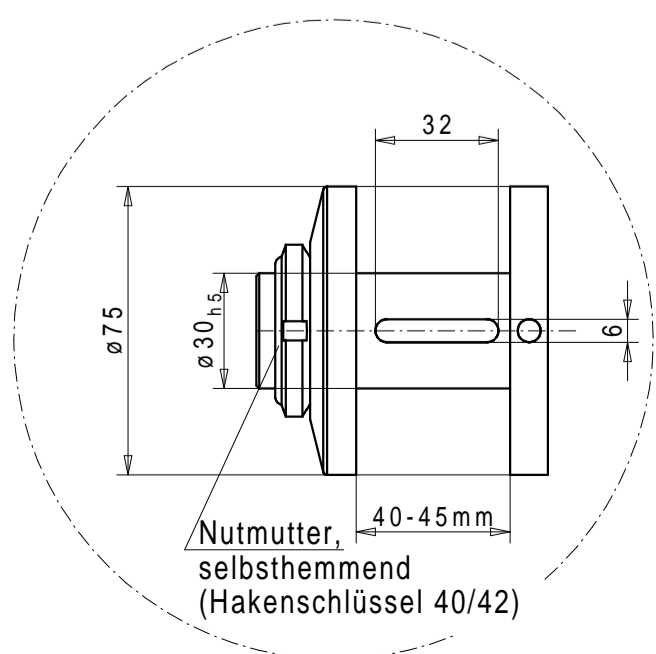

Ausführung	A	B	C	Gewichte 1,7 kW	Gewichte 2,2 kW
1,70 kW	-	-	300	-	-
2,20 kW	-	-	327	-	-
100 Hub	226,5	554,5	-	37,5	39,5
150 Hub	276,5	654,5	-	43,0	45,0
200 Hub	326,5	754,5	-	44,0	46,0