

Horizontal grooving saw
 $\varnothing 20 \times 1,5-5 \text{ mm}$

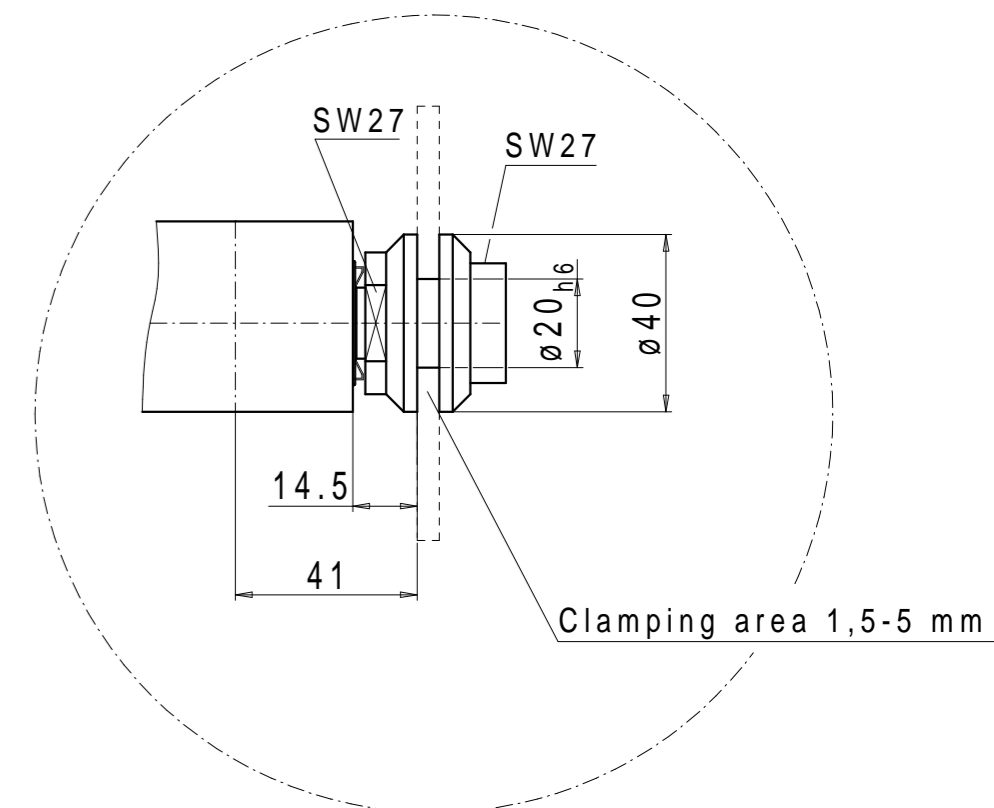

Shank receptacle
 $\varnothing 10 \text{ H7-R.H./L.H.}$

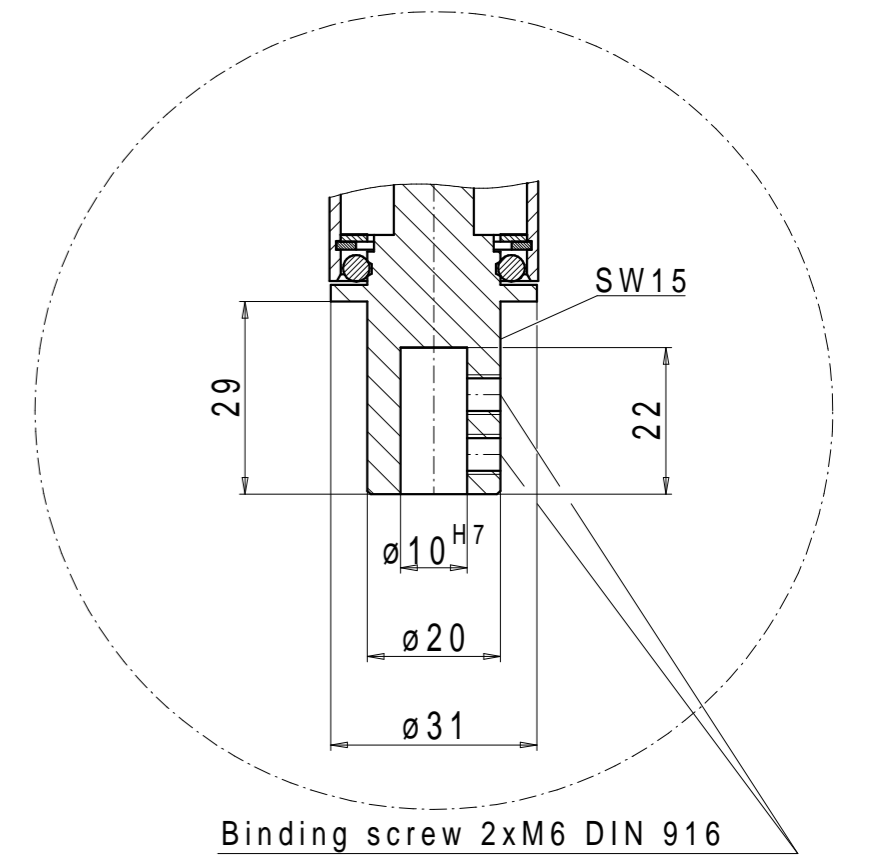

Vertical-Shank receptacle BGVT
 $\varnothing 8 \text{ H7-R.H./L.H.}$

